

Made in Holland

PITT
COOKING



Gas
Danau
Front Side

Exploded view

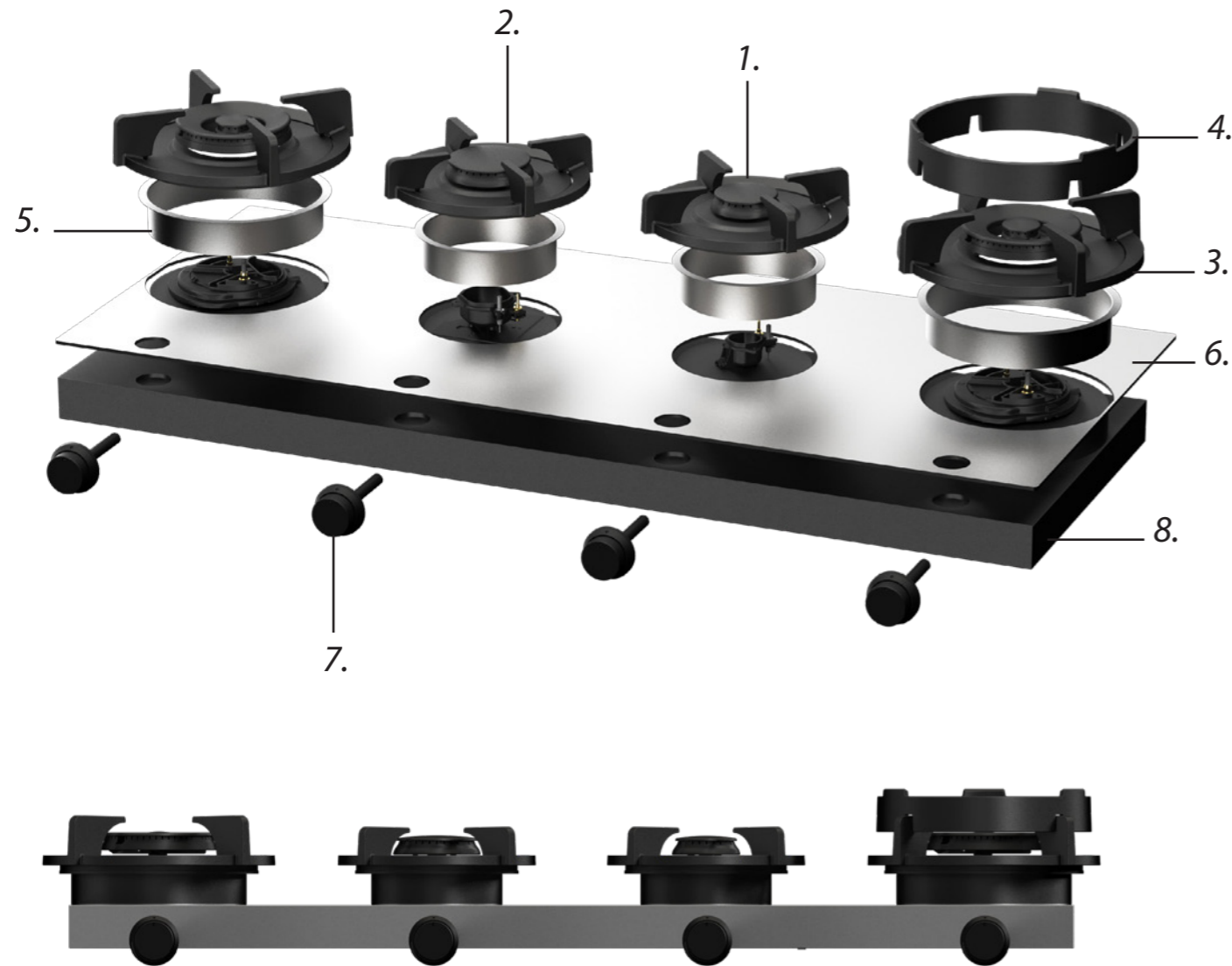

1. **Small burner**
ENAMELED CAST IRON

2. **Medium burner**
ENAMELED CAST IRON

3. **Wok-/simmer burner**
ENAMELED CAST IRON

4. **Wok ring**
ENAMELED CAST IRON

5. **Flange**
STEEL

6. **Heat conductor**
ALUMINIUM

7. **Control knob**
ANODISED ALUMINIUM

8. **Cassette unit**
GALVANIZED STEEL

Burners

Small burner

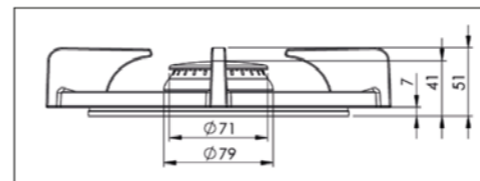
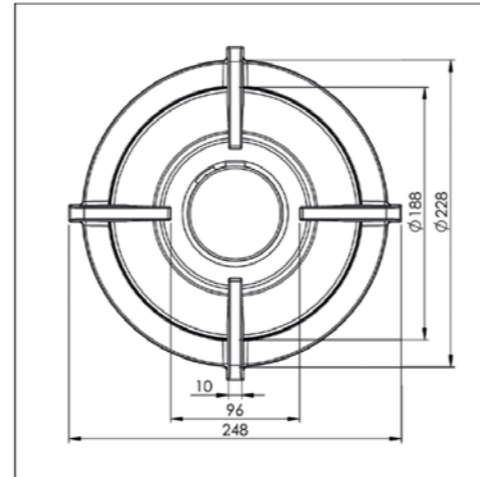

Medium burner

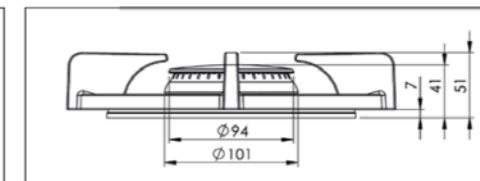
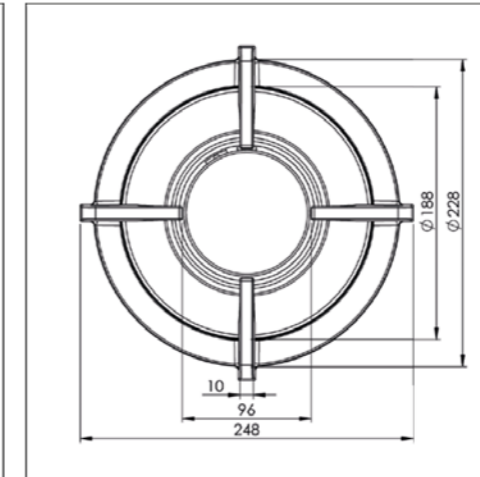

Wok-/simmer burner

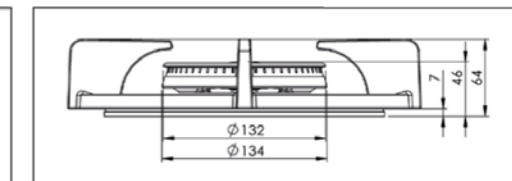
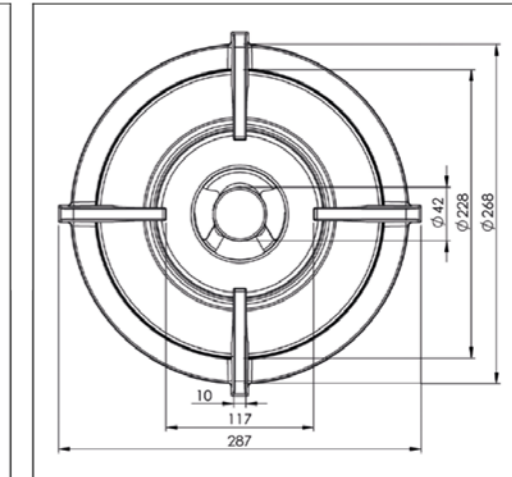

SMALL BURNERS

MIN. POWER
0,3 kW

MAX. POWER
2 kW

DIAM. BURNER
Ø 230 mm

MEDIUM BURNERS

MIN. POWER
0,3 kW

MAX. POWER
3 kW

DIAM. BURNER
Ø 230 mm

WOK-/SIMMER BURNER

MIN. POWER
0,2 kW

MAX. POWER
5 kW

DIAM. BURNER
Ø 270 mm

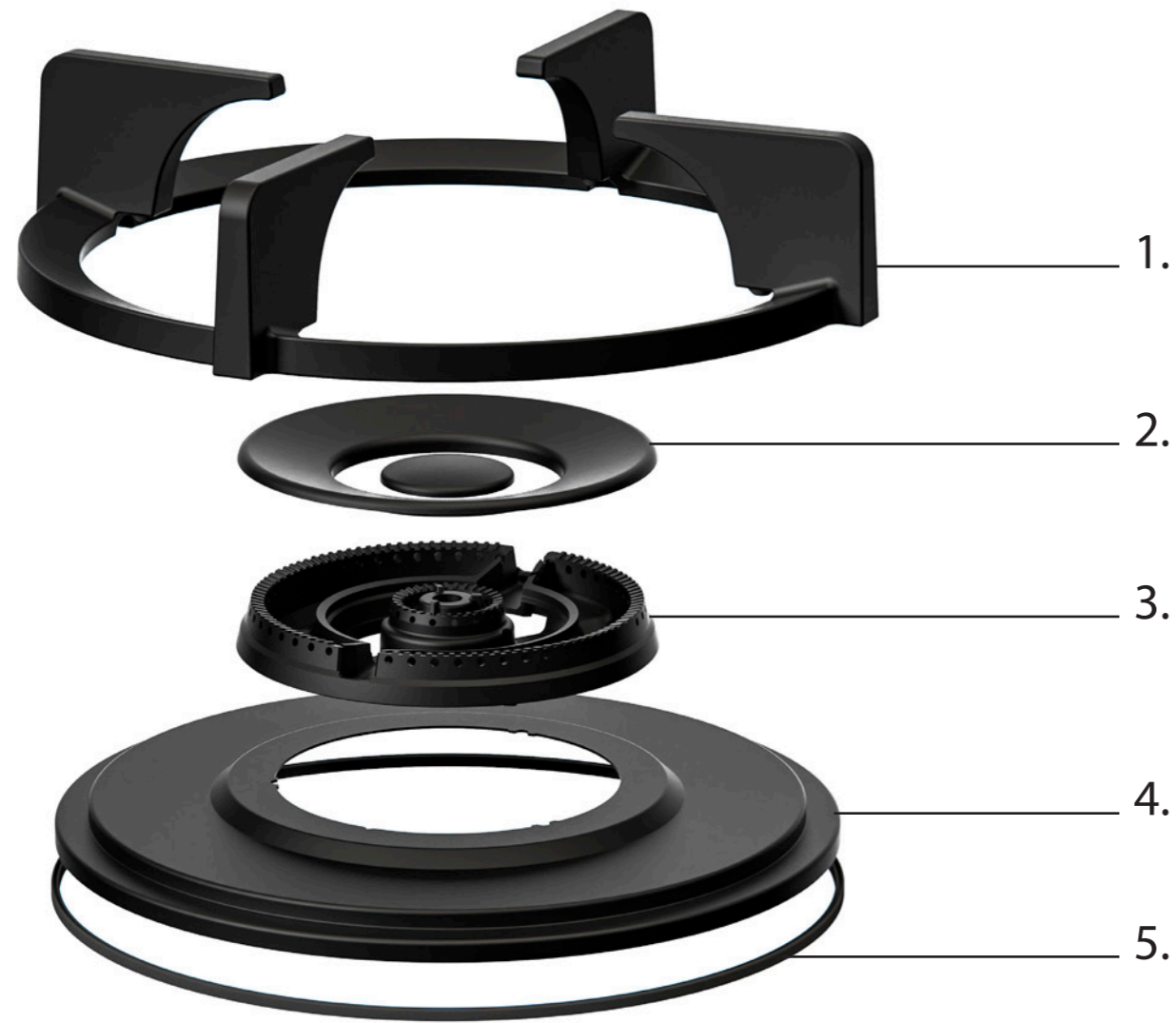

1. **Pan support**
ENAMELED CAST IRON

2. **Burner caps**
ENAMELED CAST IRON

3. **Flame spreader**
(COATED BRASS)

4. **Heat shield**
ENAMELED STEEL

5. **Silicone ring**
SILICONE

Professional edition
HEAVY BRASS BURNERS.
FOR THOSE WHO WANT TO COOK IN STYLE

Black edition
HEAVY BRASS BURNERS.
BLACK BURNERS WITH A BLACK SURFACE.
STYLISH AND REFINED.



SMALL BURNER



SMALL BURNER



MEDIUM BURNER



MEDIUM BURNER

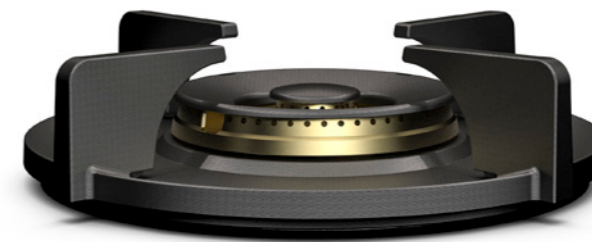

WOK-/SIMMER BURNER



WOK-/SIMMER BURNER

Control knob Front Side

Template dimensions

3D-image Front Side knob



Front view Front Side knob

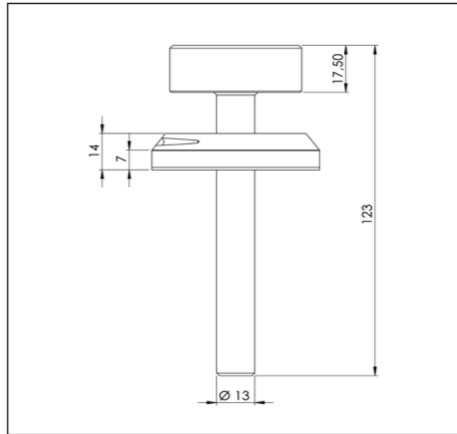

Top view Front Side knob

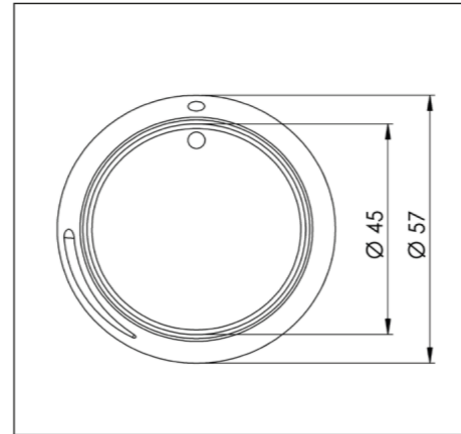

1. Determine the height of the countertop's front edge.
(Minimum height: 100 mm)
2. Determine the distance between the center of control knob and the top of the countertop.
(Minimum height: 50 mm / Maximum height: 100 mm)
3. Determine the thickness of the countertop
(Minimum thickness: 4 mm / Maximum thickness: 25 mm)

1. mm

2. mm

3. mm

***WARNING: C-size (75 mm) is a fixed size.**

*C-Size: 75 mm

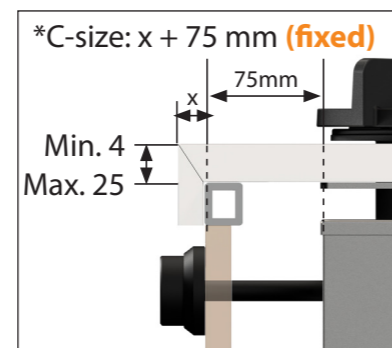
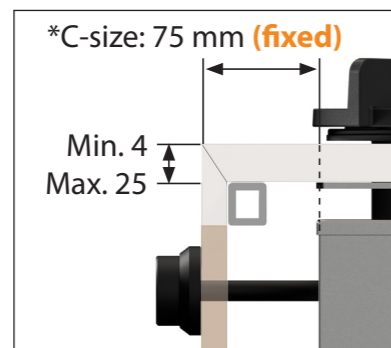
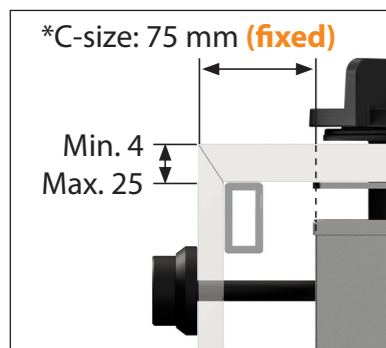
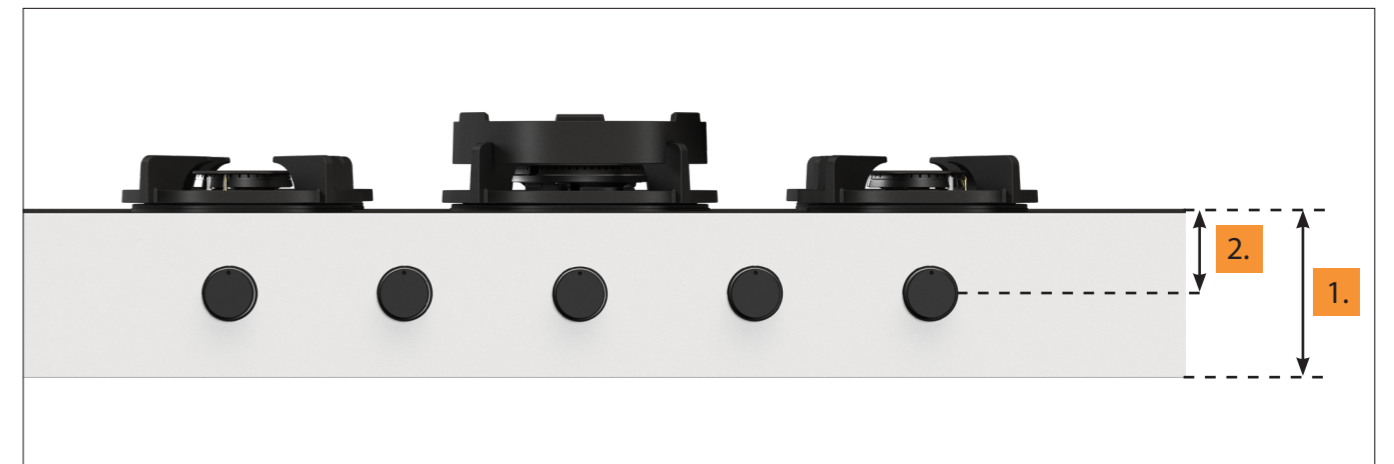
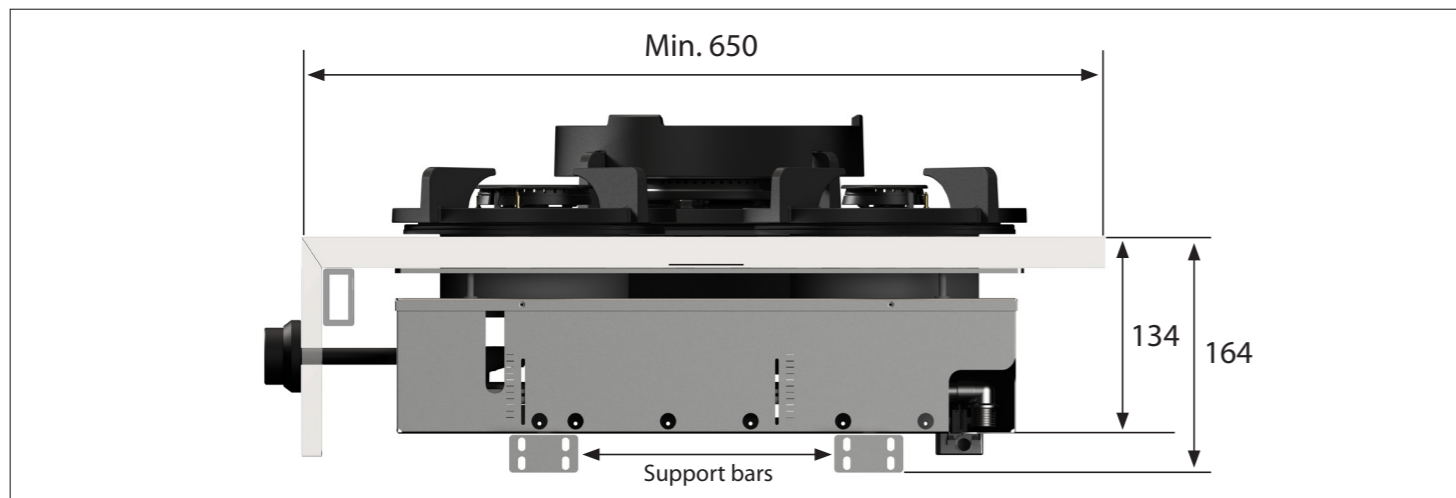

Warning! *C-Size is a fixed size

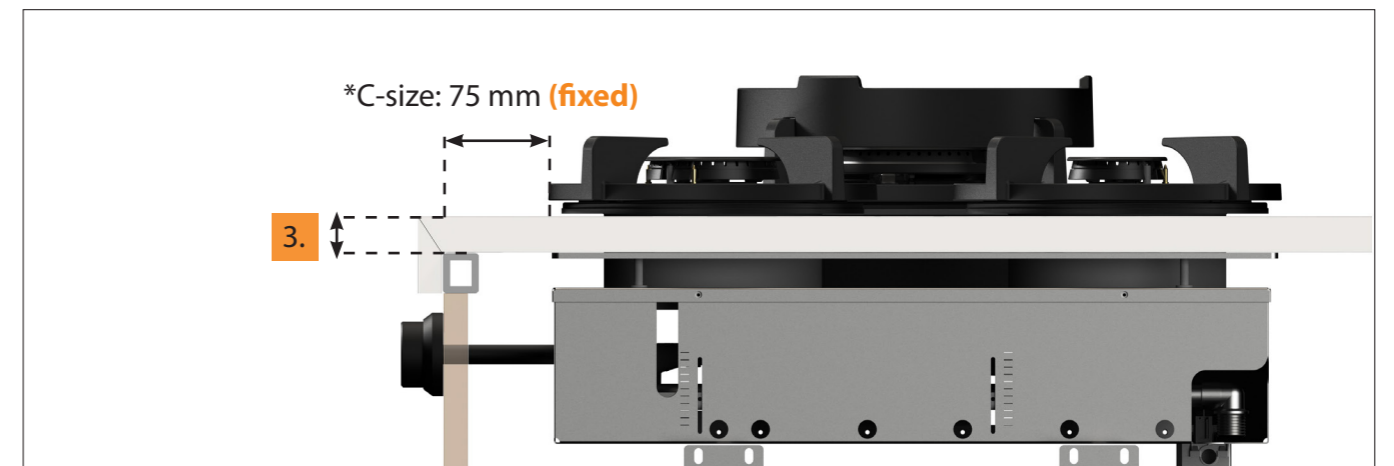

Important

- Minimal countertop depth: 650 mm
- Total height PITT unit incl. support bar set: 164mm
- Countertop thickness: 4-25 mm
- *C-size is a **fixed** size



Template dimensions -
Front Side control knob gas

This file must be completed and included with the purchase order. Scan the QR code for the file or visit the download page on our website.

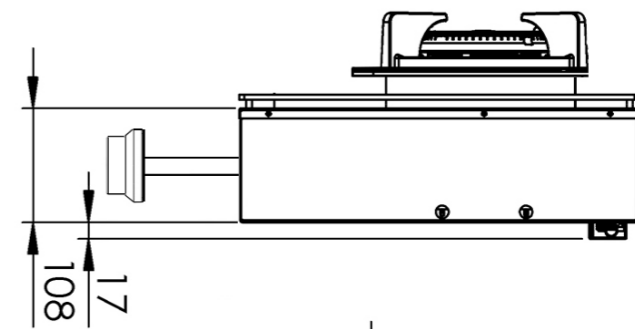
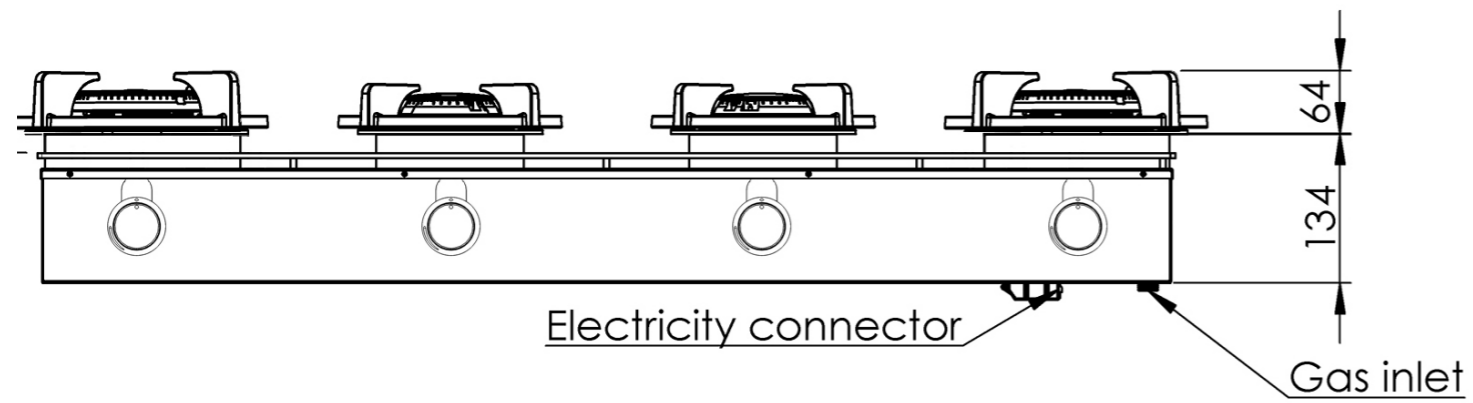
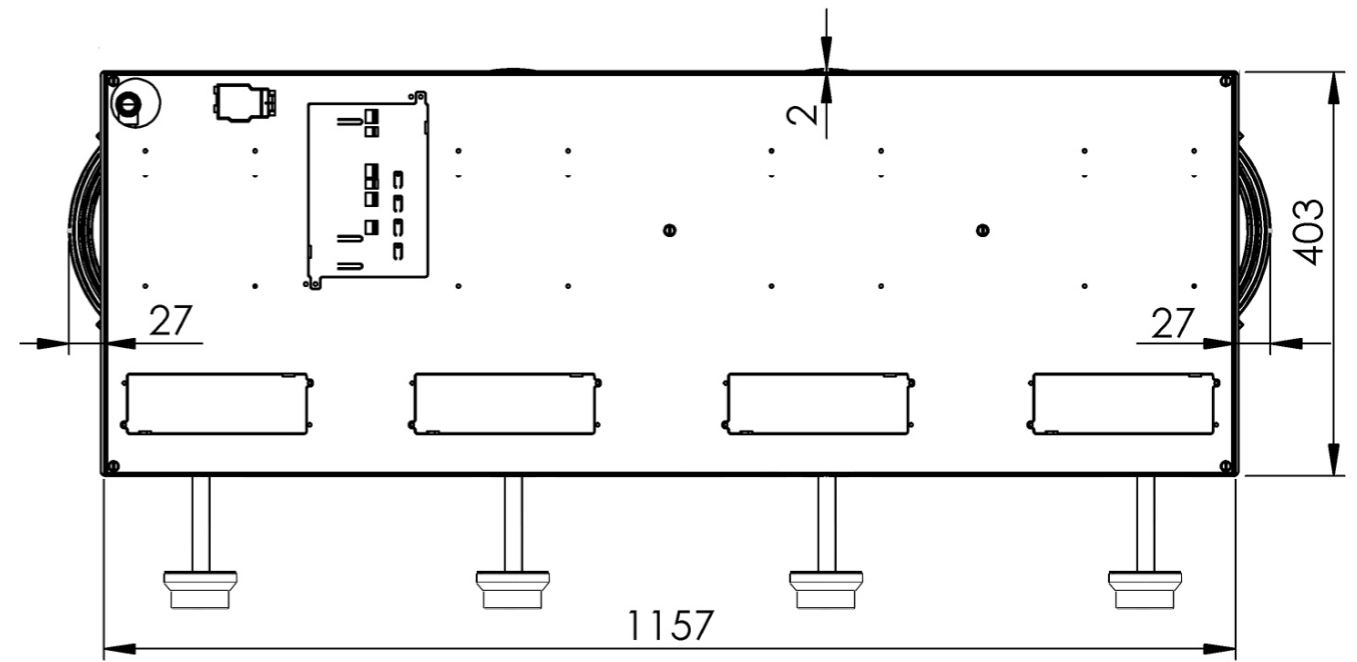
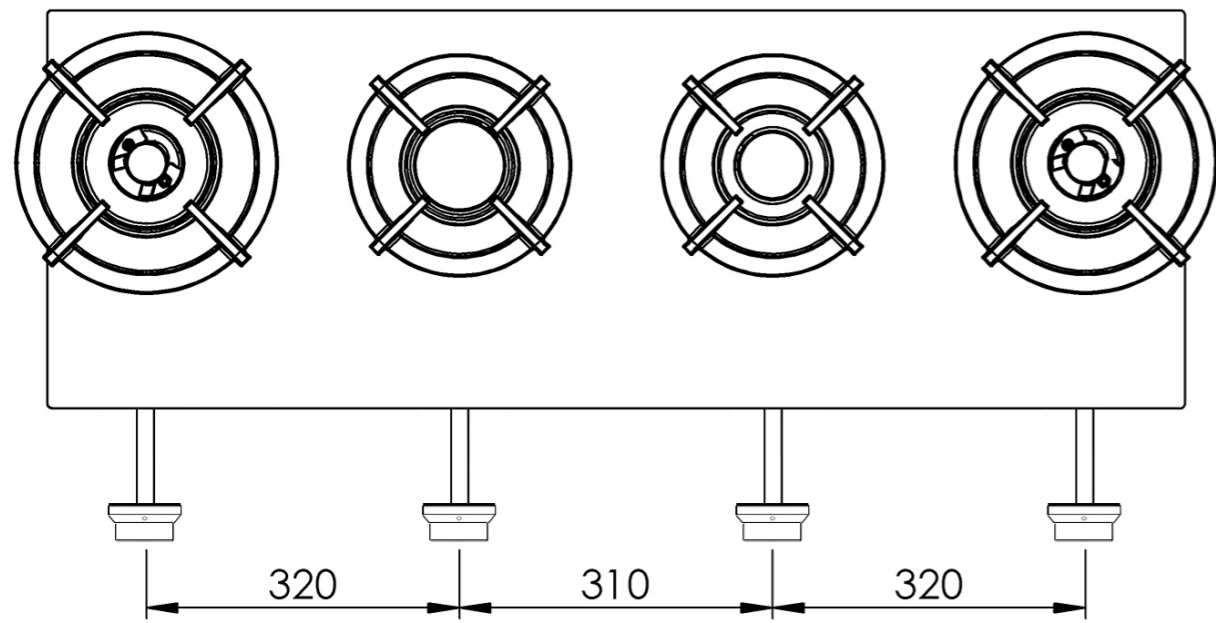

Hole pattern

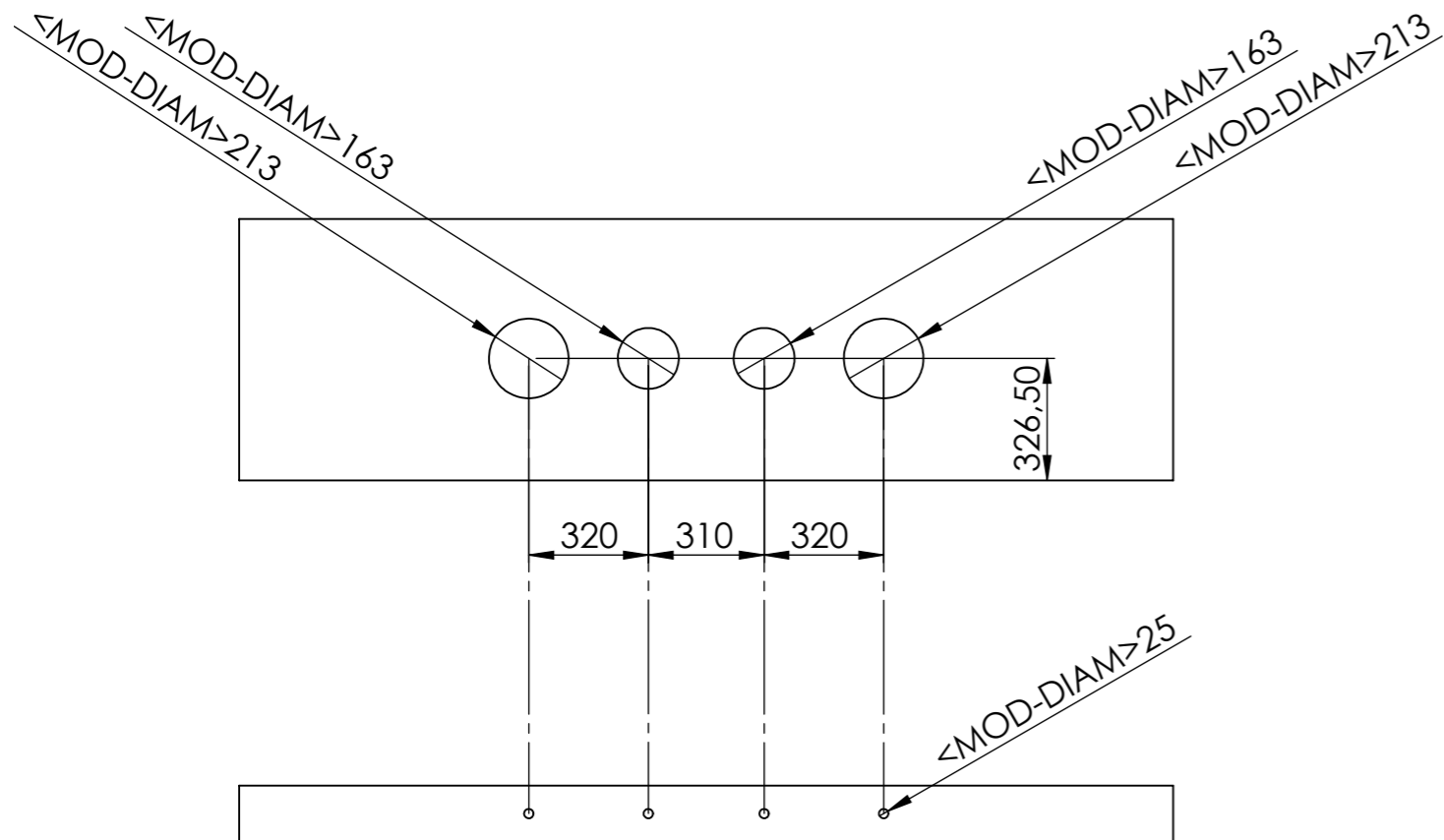

Technical specifications

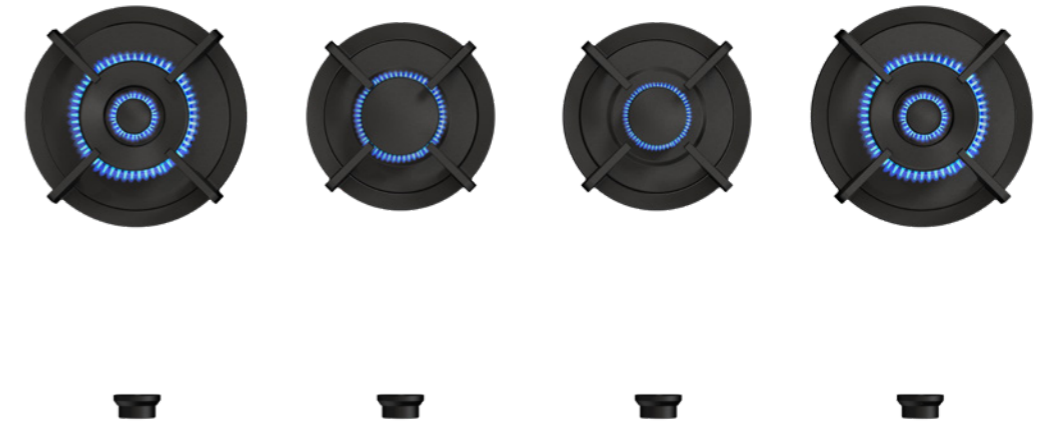

Model	Danau Front Side
Type of burners	1x burner small (0,3 - 2 kW) 1x burner medium (0,3 - 3 kW) 2x wok-/simmer burners (0,2 - 5 kW)
Editions	Professional (brass) Black (full black)
The controls	Front Side
Module dimensions (LxWxH)	403 x 1157 x 134 mm
Automatic spark ignition	✓
Flame protection	✓
Weight	25,5 kg
Wok ring	✓

Gas & Electricity

Type of gas suitable	Natural gas, LPG (Bottled gas)
Type of gas connection	½" external threads
Position gas connection	Top corner, right
Voltage	220V-110V (default) / 1,5V (battery)
Cord length	1500 mm / 591/16"



Installation and handling instructions gas



Installation manual Front Side gas



User manual gas